

EnvIRONwood™ Integrated Wood Wall Protection Systems

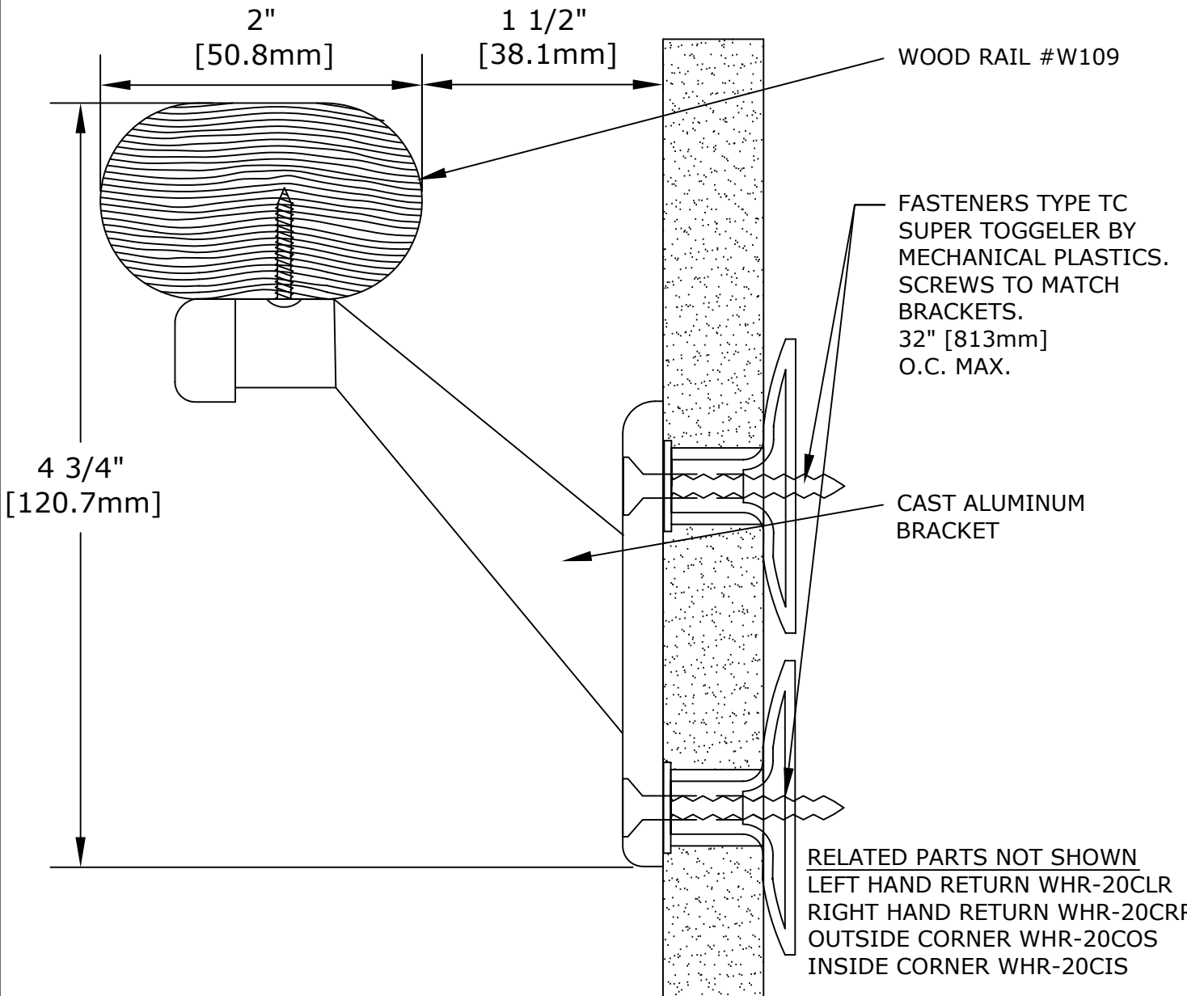

HANDRAIL SYSTEM WHR-20

IMPORTANT: USER SHALL VERIFY CONFORMANCE OF ALL CONSTRUCTIONS SHOWN WITH LOCAL CODES AND WITH REQUIREMENTS OF METAL STUD MANUFACTURER FOR RATINGS. FASTENERS AND PARTITION COMPONENTS NOT BY ARDEN ARCHITECTURAL SPECIALTIES, INC.

| | | |
|-----------|-------|--------|
| HANDRAILS | DATE: | SCALE: |
|-----------|-------|--------|

| | |
|---|-----------------|
| <p>GENERAL SPECIFICATION</p> <p>HAND RAIL : FOREST STEWARDSHIP COUNCIL (FSC) CERTIFIED KILN DRIED SELECT OR BETTER ASH, OAK, OR MAPLE, FURNISHED IN 6'-14' [1.8M-4.3M] RANDOM LENGTHS WITH CAST ALUMINUM BRACKETS</p> <p>RETURNS AND CORNERS: PREFABRICATED AND STAINED TO MATCH. DUE TO NATURAL VARIATIONS IN WOOD, GRAIN MAY NOT MATCH EXACTLY.</p> <p>BRACKETS: CAST ALUMINUM WITH BRONZE (US-10), BRASS (US-3) OR CLEAR (US-27) ANODIZED FINISH</p> <p>FINISH : STAINED OR CLEAR FINISH. SEALED AND FINISHED WITH TWO COATS OF WATER WHITE CONVERSION VARNISH.</p> | PROJECT: |
| | ARCHITECT: |
| | CONTRACTOR: |
| | REPRESENTATIVE: |

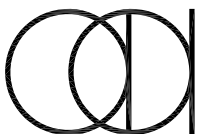

Arden
Architectural
Specialties, Inc.™

151 FIFTH AVE. NW SUITE J ST. PAUL, MN 55112-3268
 TOLL-FREE 800.521.1826 TEL 651.631.1607 FAX 651.631.0251

| | | | |
|-----------|-----------|---------|----------|
| CUSTOMER: | CUST. NO: | JOB NO: | SHEET OF |
|-----------|-----------|---------|----------|