

Wallwear® Integrated Wall Protection Systems

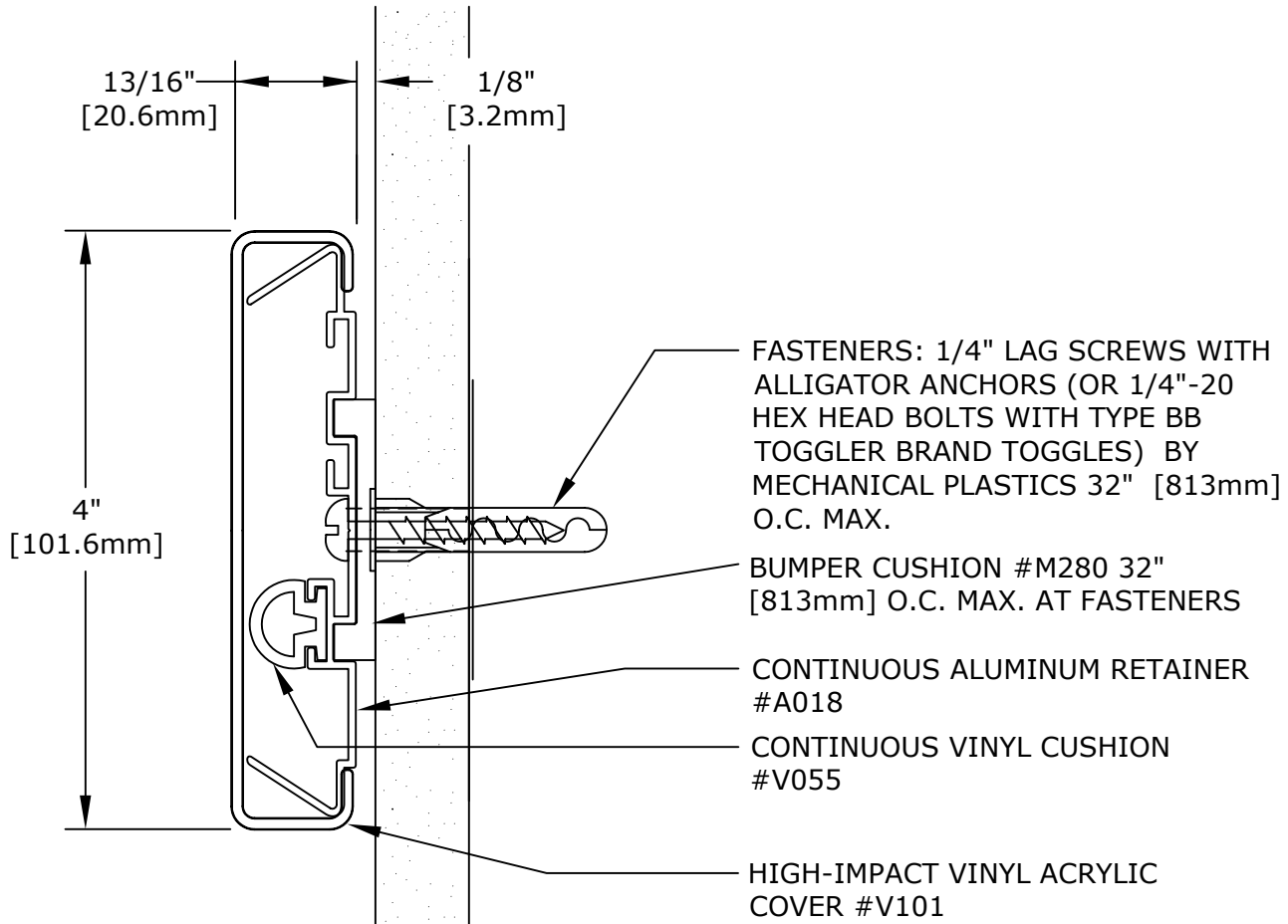

RELATED PARTS NOT SHOWN
 END RETURN #CRS-4CR
 OUTSIDE CORNER #CRS-4COS

CRASH RAIL CRS-4

IMPORTANT: USER SHALL VERIFY CONFORMANCE OF ALL CONSTRUCTIONS SHOWN WITH LOCAL CODES AND WITH REQUIREMENTS OF METAL STUD MANUFACTURER FOR RATINGS. FASTENERS AND PARTITION COMPONENTS NOT BY ARDEN ARCHITECTURAL SPECIALTIES, INC.

CRASH RAILS		DATE:	SCALE:
GENERAL SPECIFICATION RETAINER: ALUMINUM ALLOY TYPE 6063-T5, MILL FINISH .062" [1.57mm] THICK COVER: HIGH-IMPACT VINYL ACRYLIC, IN ACCORDANCE WITH ASTM D 4226 AND ASTM D 256, .078" [1.98mm] THICK CONTINUOUS LENGTH AVAILABLE: 20' [6.1M] MAXIMUM		PROJECT:	
		ARCHITECT:	
		CONTRACTOR:	
		REPRESENTATIVE:	



151 FIFTH AVE. NW SUITE J ST. PAUL, MN 55112-3268
 TOLL-FREE 800.521.1826 TEL 651.631.1607 FAX 651.631.0251

CUSTOMER:	CUST. NO:	JOB NO:	SHEET OF
-----------	-----------	---------	----------