

INSTALLATION INSTRUCTIONS DOOR PROTECTION SYSTEM CGS-3D

STORAGE, HANDLING, AND ENVIRONMENTAL CONDITIONS:

1. All materials shipped unassembled. Store vertically or on a flat horizontal surface.
2. Begin installation only after finish construction has been completed and building interior has been within the temperature range intended for continued use for at least 24 hours. Cut vinyl and aluminum components to fit only after they have been at temperature intended for continued use for 24 hours.

INSTALLATION:

1. Measure and mark location of top cap on the door jamb. The distance from floor up to lip of the top cap should be the same as the length of the vinyl cover. Do not install top cap at this time.
2. Install retainer. Place bottom of aluminum retainer on floor, and secure retainer to door jamb with # 6 dry-wall screws inserted through factory drilled holes in retainer legs. Be sure to allow space for later installation of the top cap.
3. Install top cap. Place top cap in position, and lay factory provided perpetuwall chip on top of cap to determine how much it must be trimmed. Chip is designed to be glued into the groove on the inside radius of top cap to provide a more finished look and to prevent debris from falling into the space behind the door jamb protector. After trimming, glue chip in place with pvc cement provided, and attach top cap to door jamb with #6 dry-wall screws.
4. Install vinyl cover on retainer. Hook one edge of cover on retainer and rotate sidward, pushing firmly to snap over other retainer edge.
5. Clean surface of the door jamb protector with a mild detergent. Do not use powdered cleansers, as they may leave residue embedded in the textured surface of the cover.

ASSEMBLY DRAWING

CGS-3D

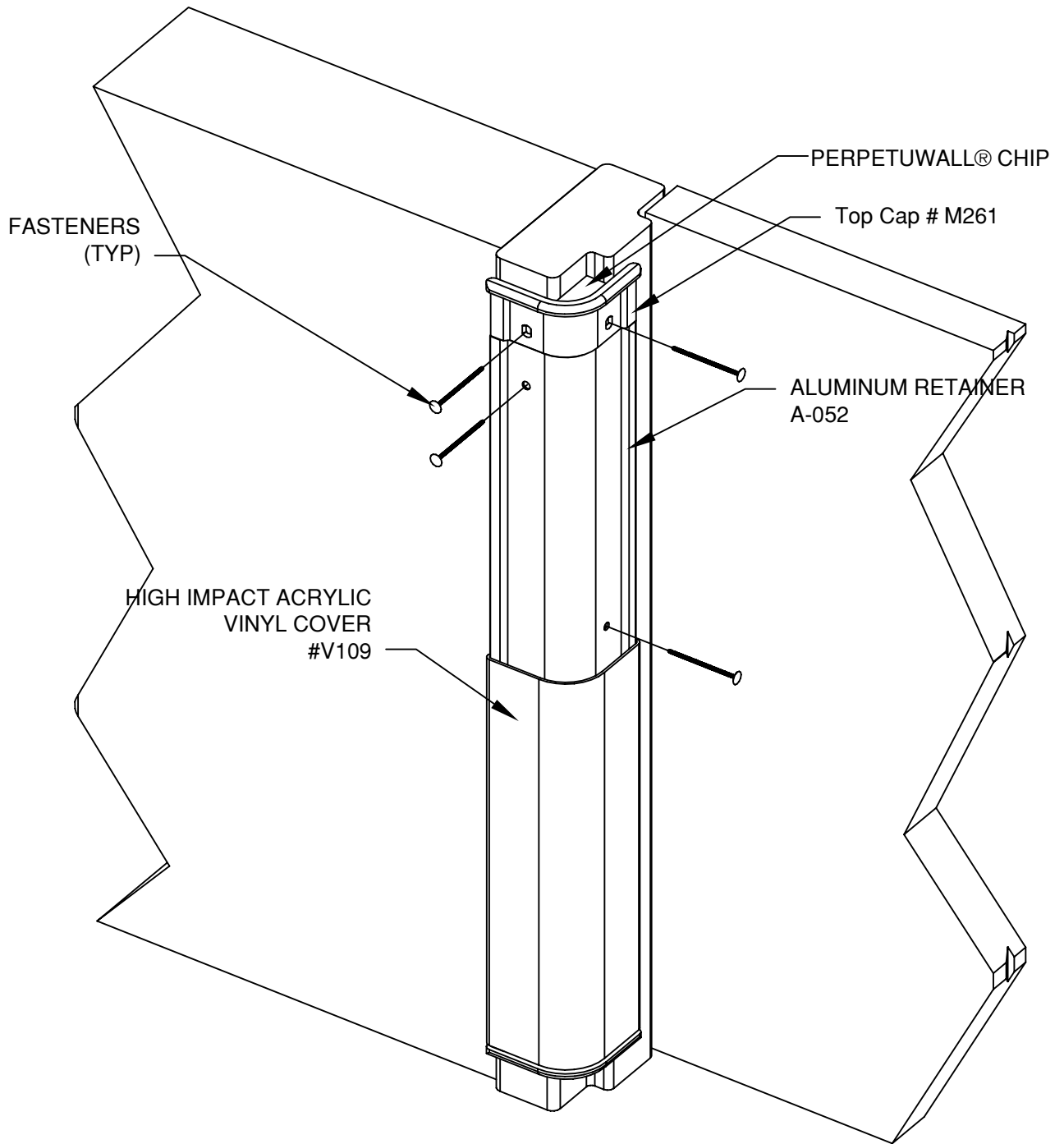

NOTES:

1. FACTORY-DRILLED FASTENER HOLES ON RETAINER LEGS ARE STAGGERED 8" [203.2mm] O.C.

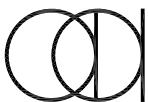

Arden
Architectural
Specialties, Inc.™

151 FIFTH AVE. NW SUITE J ST. PAUL, MN 55112-3268
TOLL-FREE 800.521.1826 TEL 651.631.1607 FAX 651.631.0251

PLAN VIEW CGS-3D

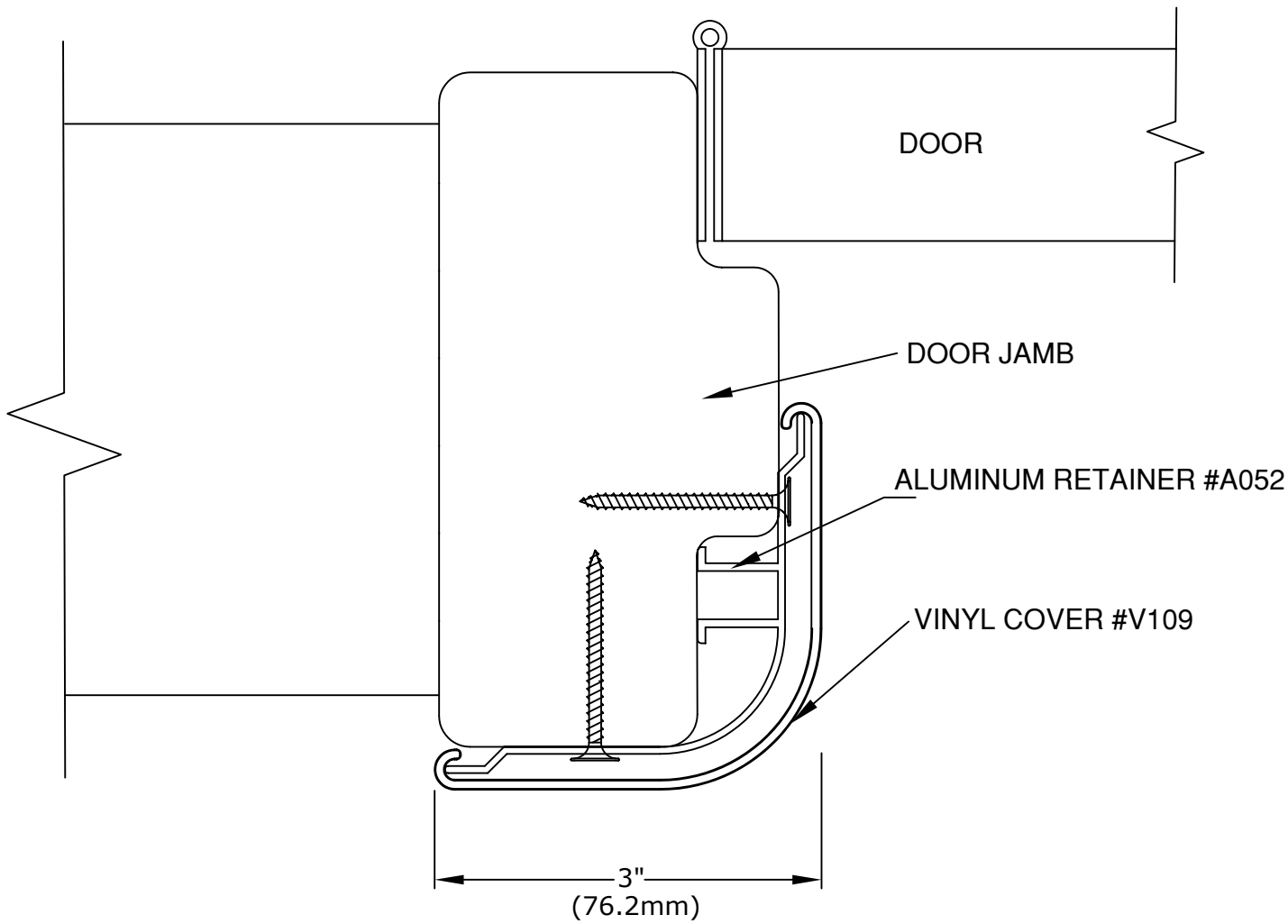

NOT SHOWN
END CAPS #M261
PERPETUWALL® CHIP

COVER INSTALLATION

1. HOOK OVER ONE RETAINER EDGE.
2. ROTATE SIDEWARD, PUSHING FIRMLY TO SNAP OVER OTHER RETAINER EDGE.

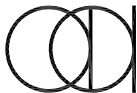
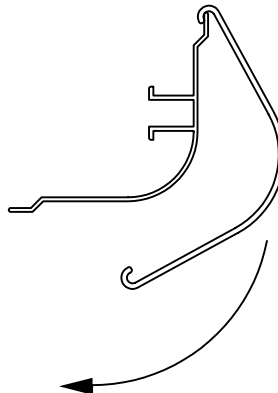

Arden
Architectural
Specialties, Inc.™

151 FIFTH AVE. NW SUITE J ST. PAUL, MN 55112-3268
TOLL-FREE 800.521.1826 TEL 651.631.1607 FAX 651.631.0251