

INSTALLATION INSTRUCTIONS CRASH RAIL SYSTEMS

CRE-4, CRE-8

STORAGE, HANDLING & ENVIRONMENTAL CONDITIONS:

1. All materials shipped unassembled. Store vertically or on flat horizontal surface.
2. Begin installation only after finish construction has been completed and building interior has been within temperature range intended for continued use for at least 24 hours. Cut vinyl and aluminum components to fit only after they have been at temperature intended for continued use for 24 hours.

INSTALLATION:

1. Measure and mark centerline of rail system on wall or partition. Locate this centerline by subtracting [CRE-4: 2" [50.8mm]][CRE-8: 4" [101.6mm]] from height of top of rail on wall or partition.
2. CRE-8 ONLY: Measure and mark fastener centerlines on wall or partition. locate these centerlines 1-1/2" [38.1mm] above and below system centerline.
3. Measure and mark retainer ends, and joints between abutting retainer lengths, if any, on wall or partition (see Standard Plan Detail on reverse side).
4. Measure and mark fasteners holes on wall or partition. Locate holes for CRE-4 on system centerline, for CRE-8 on both fastener centerlines staggered top and bottom. Space holes 32" [812.8mm] O.C. max., unless otherwise specified, and at distances from retainer ends and butt joints as shown (see Standard Plan Detail).
5. Measure and cut retainer lengths. Use longest practical lengths to minimize number of joints. Carefully cut to achieve hairline joints between abutting lengths. Verify that cut lengths conform exactly with lengths marked on wall or partition.
6. Pre-drill fastener holes in wall or partition at locations marked. Make hole diameter as small as possible, allowing for fasteners. For most drywall applications, we recommend 1/4"-20 bolts and 1/4" size BB strap-type Toggler brand toggles by Mechanical Plastics. For most masonry applications, we recommend 1/4" lag screws and Toggler brand "alligator" anchors, size A6, by Mechanical Plastics.
7. Pre-drill holes in retainer lengths to align with holes in wall or partition. Make hole diameter as small as possible, allowing for fasteners.
8. Assemble retainers. Splice abutting retainer lengths, if any, using manufacturer-provided splices and screws; abut tightly to achieve hairline joints. Slide vinyl cushions into retainer slots and cut to fit. Insert tabs on returns and corners into retainers, clamp into place, and secure with #8x1/2" sheet metal screws or 1/8" pop rivets.
9. Secure rail assemblies to wall or partition. Assemble fasteners, insert through holes in retainer and bumper cushions and into holes in wall or partition, and secure per fastener manufacturer's printed instructions.
10. Install cover. Carefully locate cover joints so that they are not directly over retainer splices, as this can create improper alignment of adjacent cover lengths. Measure and cut cover lengths to fit between returns and corners exactly. Use longest practical lengths to minimize number of joints. Do not align cover joints directly over aluminum retainer joints. Secure cover to retainer by hooking over retainer top and snapping over retainer bottom. Make all joints neat and hairline tight.
11. Use mild detergent to clean soiled surfaces. Do not use powdered cleansers, as they may leave a residue embedded in cover surface.



Arden
Architectural
Specialties, Inc.™

151 FIFTH AVE. NW SUITE J ST. PAUL, MN 55112-3268
TOLL-FREE 800.521.1826 TEL 651.631.1607 FAX 651.631.0251

PARTS LIST

CRE-4, CRE-8

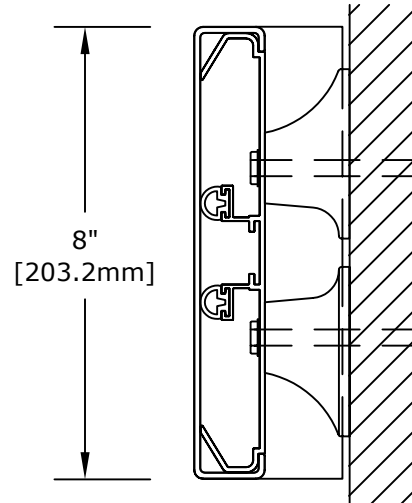
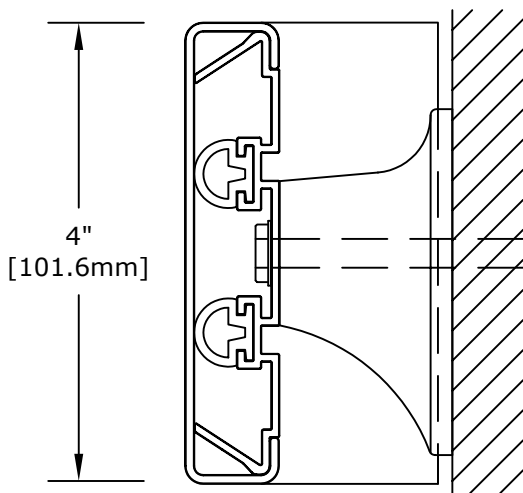

CRE-4

- ALUMINUM RETAINER - #A018
- VINYL ACRYLIC COVER - #V101
- L.H. END RETURN - #CRE-4CLR
- R.H. END RETURN - #CRE-4CRR
- OUTSIDE CORNER - #CRE-4COS
- ALUMINUM SPLICE PLATE - #A023
- VINYL CUSHION - #V055
- MOUNTING BRACKET - #M290
- #8 X 1/2" S.M.S. - #A300

CRE-8

- ALUMINUM RETAINER - #A021
- VINYL ACRYLIC COVER - #V100
- L.H. END RETURN - #CRE-8CLR
- R.H. END RETURN - #CRE-8CRR
- OUTSIDE CORNER - #CRE-8COS
- ALUMINUM SPLICE PLATE - #A023
- VINYL CUSHION - #V055
- MOUNTING BRACKET - #M290
- #8 X 1/2" S.M.S. - #A300

COVER INSTALLATION

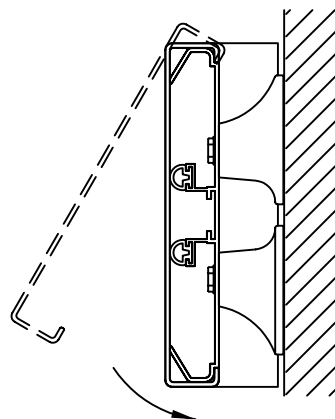

1. HOOK OVER TOP OF RETAINER.
2. ROTATE DOWNWARD, PUSHING FIRMLY TO SNAP OVER RETAINER BOTTOM.

STANDARD PLAN DETAIL

CRE-4, CRE-8

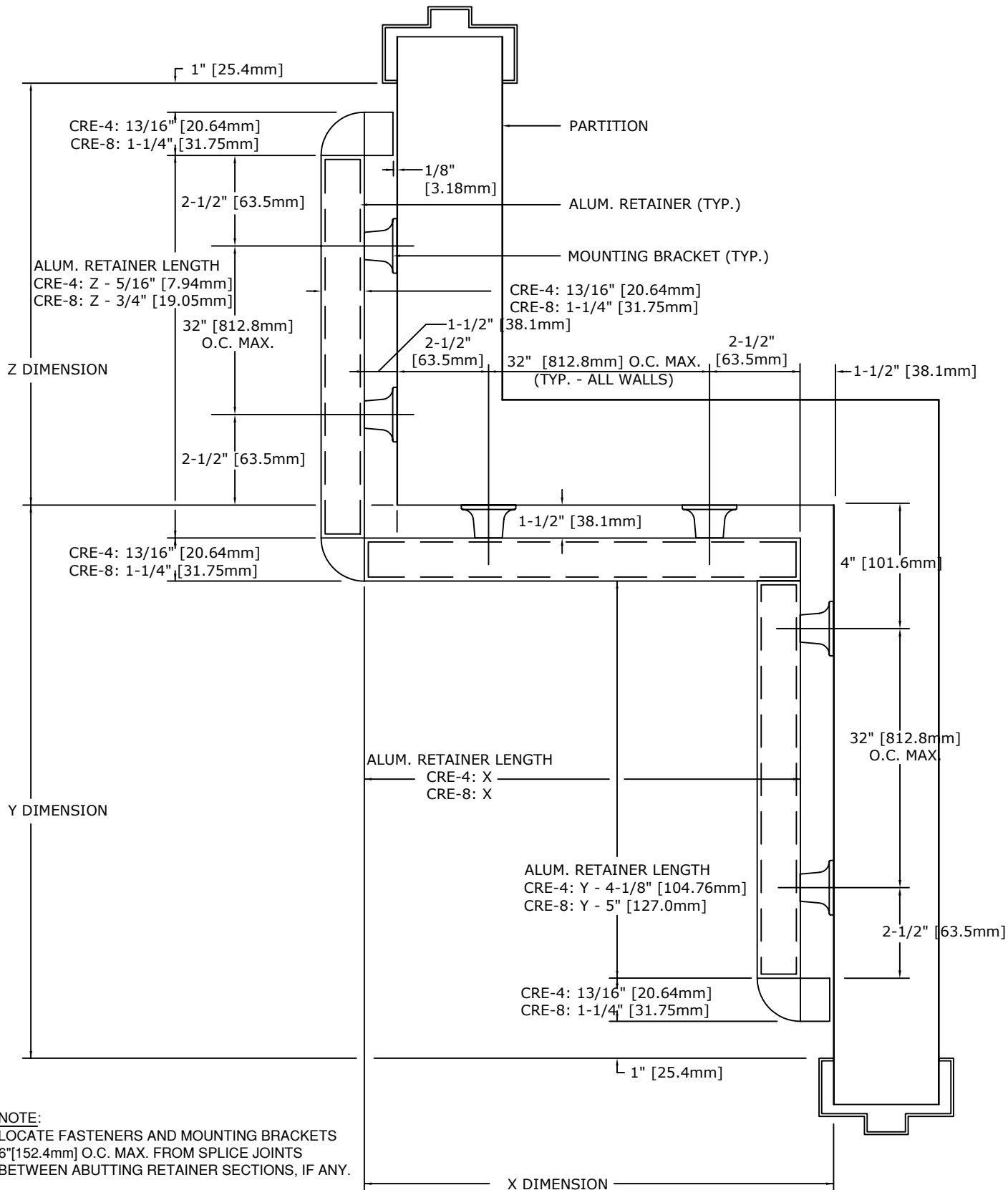

NOTE:
LOCATE FASTENERS AND MOUNTING BRACKETS
6" [152.4mm] O.C. MAX. FROM SPLICE JOINTS
BETWEEN ABUTTING RETAINER SECTIONS, IF ANY.

FASTENER HEIGHT

CRE-4, CRE-8 (CRE-8 SHOWN)

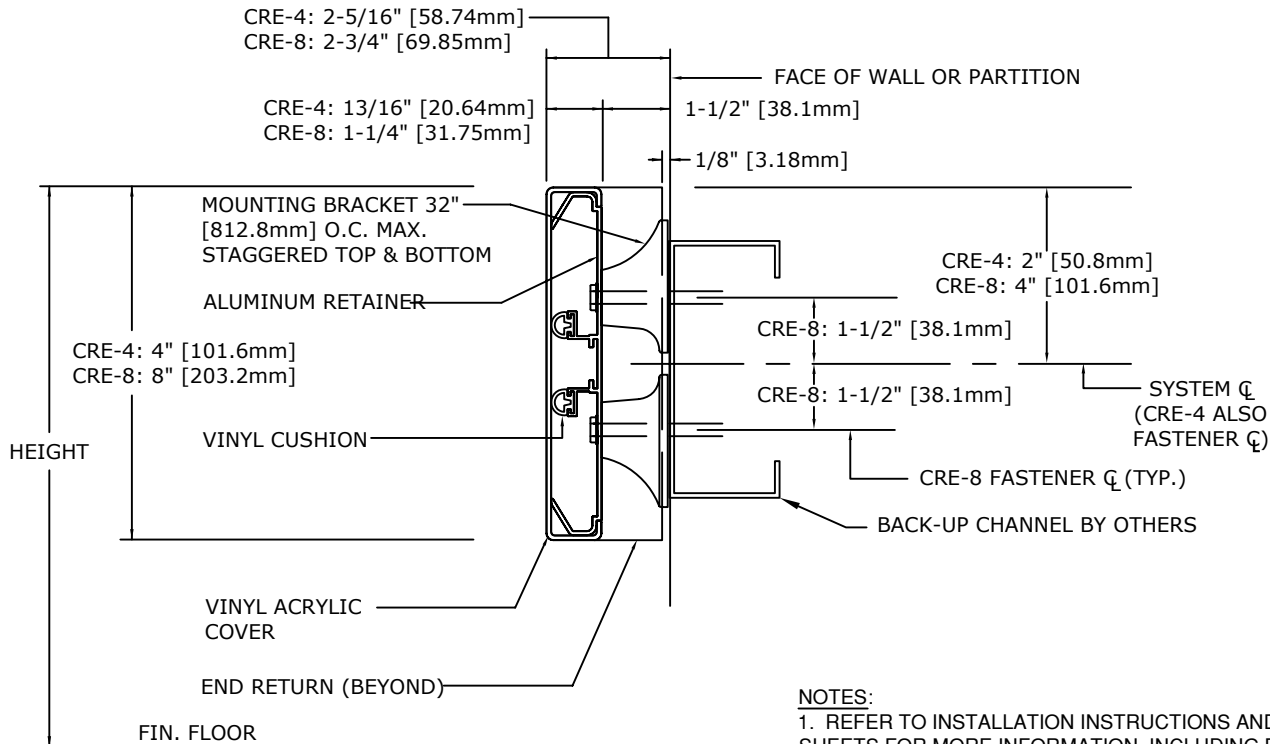

NOTES:

1. REFER TO INSTALLATION INSTRUCTIONS AND DETAIL SHEETS FOR MORE INFORMATION, INCLUDING PART NUMBERS.
2. ON WALL OR PARTITION, MARK HEIGHT OF TOP OF RAIL (FROM FINISH FLOOR), THEN SUBTRACT DISTANCE FROM TOP OF RAIL TO FASTENER CENTERLINE.

IMPORTANT: USER SHALL VERIFY CONFORMANCE OF ALL CONSTRUCTIONS SHOWN WITH LOCAL CODES AND WITH REQUIREMENTS OF METAL STUD MANUFACTURER FOR RATINGS. FASTENERS AND PARTITION COMPONENTS NOT BY ARDEN ARCHITECTURAL SPECIALTIES, INC.

TYPICAL FASTENING CONDITIONS SHOWN BELOW

<p>1 LAYER GYP. BD.</p> <p>1/4"-20 X 2-3/4" BOLT AND TYPE BB TOGGLER BY MECHANICAL PLASTICS</p> <p>QTY:</p>	<p>2 LAYERS GYP. BD.</p> <p>1/4"-20 X 2-3/4" BOLT AND TYPE BB TOGGLER BY MECHANICAL PLASTICS</p> <p>QTY:</p>	<p>MASONRY</p> <p>1/4" X 3" LAG SCREW AND TYPE AF6 ALLIGATOR ANCHORS BY MECHANICAL PLASTICS</p> <p>QTY:</p>	<p>GYP. BD. & MASONRY</p> <p>1/4" X 3" LAG SCREW AND TYPE AF6 ALLIGATOR ANCHORS BY MECHANICAL PLASTICS</p> <p>QTY:</p>
---	--	---	--

SPECIFICATION:

GENERAL: FURNISH AND INSTALL CRASH RAIL SYSTEM(S) BY ARDEN ARCHITECTURAL SPECIALTIES, INC., AS SHOWN AND SPECIFIED.

INSTALLATION: SECURE TO WALL OR PARTITION IN ACCORDANCE WITH MANUFACTURER'S PRINTED INSTRUCTIONS. USE FASTENERS DESIGNED AND APPROVED FOR PURPOSE INTENDED, SPACED 32 INCHES [812.8mm] O.C. MAX, UNLESS SPECIFIED OTHERWISE. INSTALL SYSTEM IN ACCORDANCE WITH ALL CODES HAVING JURISDICTION.



Arden
Architectural
Specialties, Inc.™

151 FIFTH AVE. NW SUITE J ST. PAUL, MN 55112-3268
TOLL-FREE 800.521.1826 TEL 651.631.1607 FAX 651.631.0251