

EnvIRONwood™ Integrated Wood Wall Protection Systems

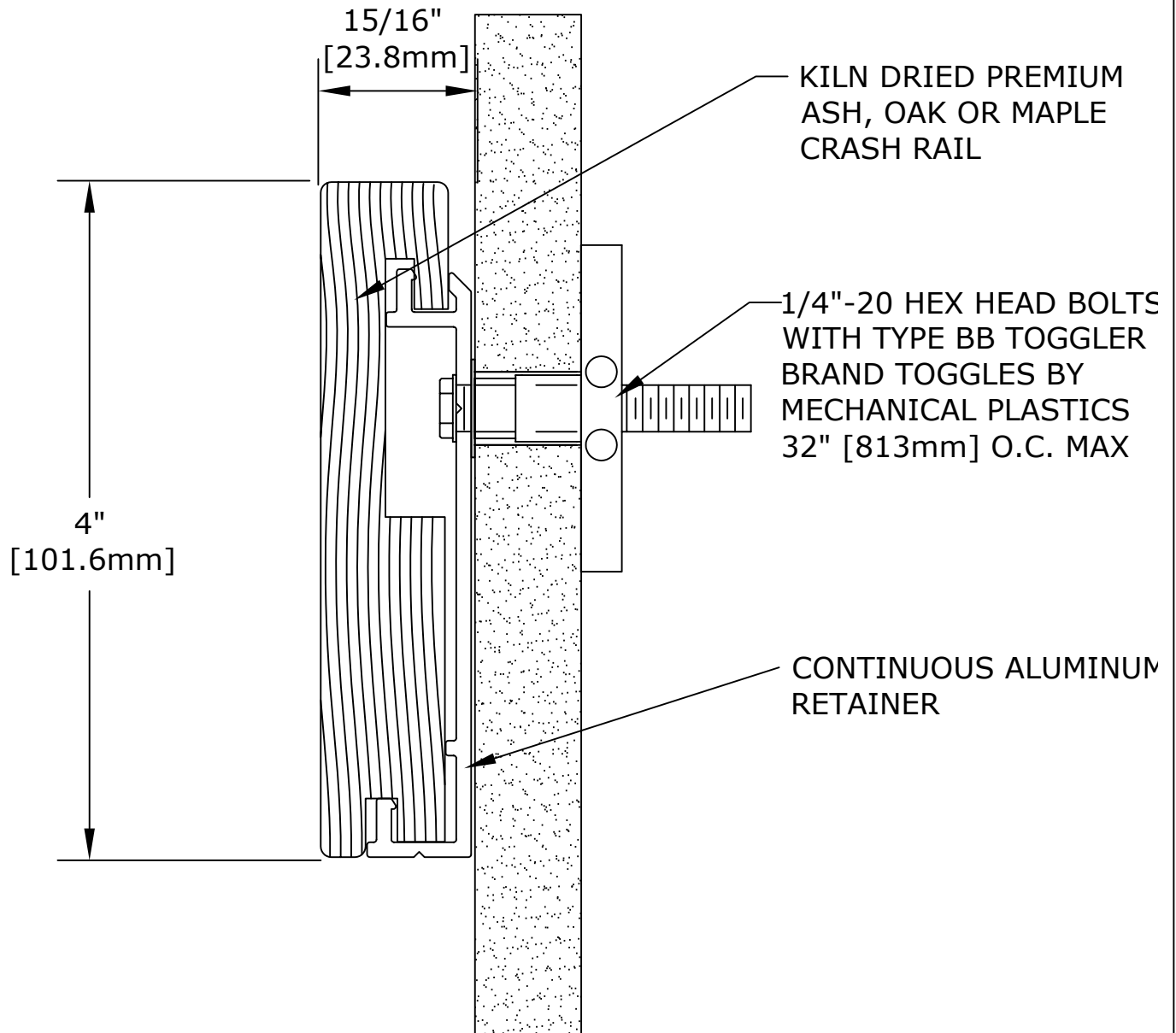

CRASH RAIL WCRS-4

IMPORTANT: USER SHALL VERIFY CONFORMANCE OF ALL CONSTRUCTIONS SHOWN WITH LOCAL CODES AND WITH REQUIREMENTS OF METAL STUD MANUFACTURER FOR RATINGS. FASTENERS AND PARTITION COMPONENTS NOT BY ARDEN ARCHITECTURAL SPECIALTIES, INC.

CRASH RAIL

DATE:

SCALE:

GENERAL SPECIFICATIONS:

ALUMINUM BUMPER RETAINER: ALUMINUM ALLOY TYPE 6063-T5
CRASH RAIL: FOREST STEWARDSHIP COUNCIL (FSC) CERTIFIED KILN-DRIED PREMIUM ASH, OAK, OR MAPLE, FURNISHED IN 6'-14' [1.83M-4.27M] RANDOM LENGTHS
END PLATES: ALUMINUM ALLOY TYPE 6063-T5 CLEAR ANODIZED
FINISH: STAINED OR CLEAR FINISH. SEALED AND FINISHED WITH TWO COATS OF WATER WHITE CONVERSION VARNISH.

PROJECT:

ARCHITECT:

CONTRACTOR:

REPRESENTATIVE:

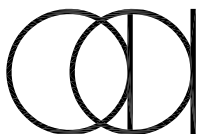

Arden
Architectural
Specialties, Inc.™

151 FIFTH AVE. NW SUITE J ST. PAUL, MN 55112-3268
 TOLL-FREE 800.521.1826 TEL 651.631.1607 FAX 651.631.0251

CUSTOMER:

CUST. NO:

JOB NO:

SHEET OF