

# Wallwear® Integrated Wall Protection Systems

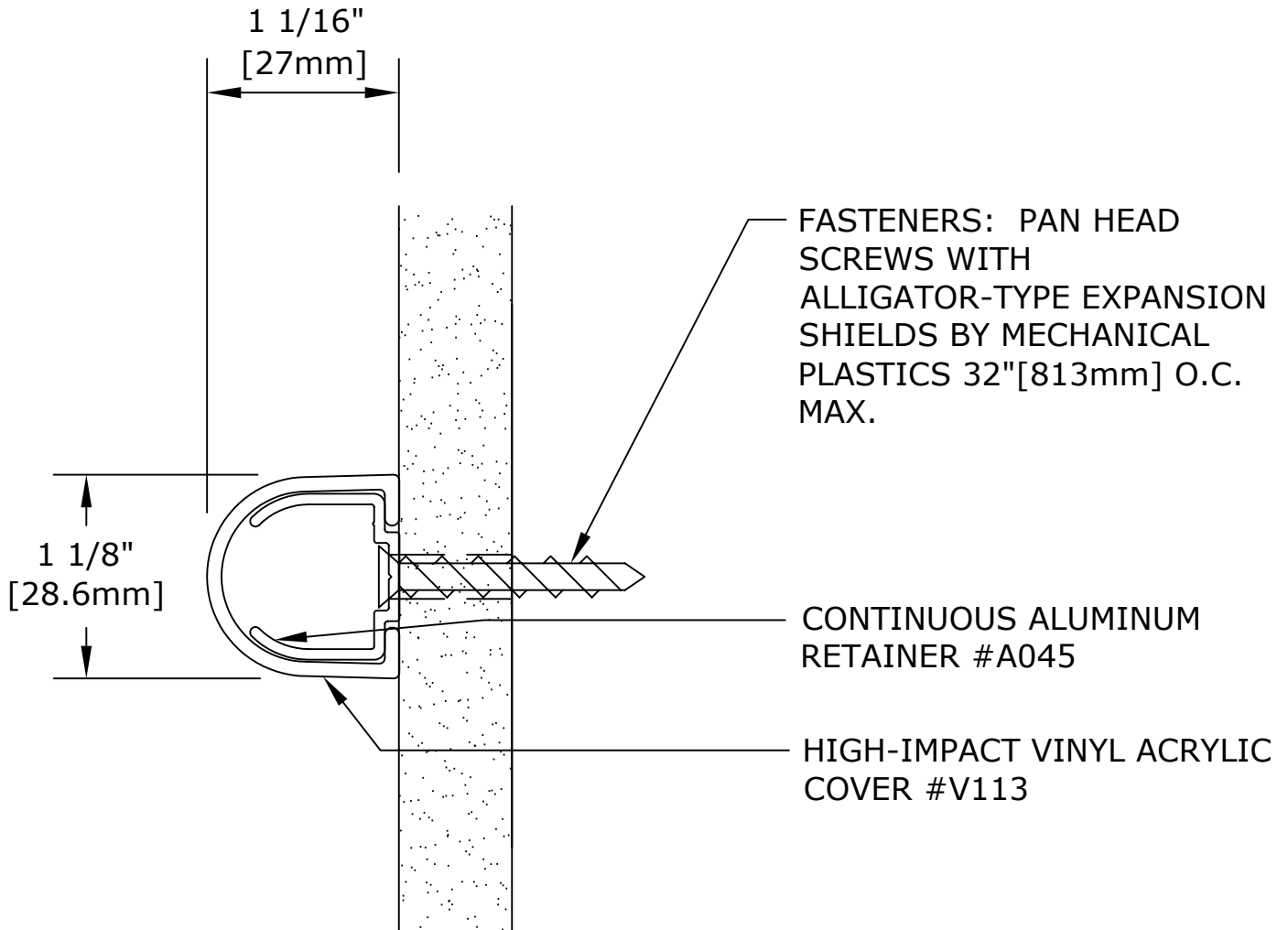

RELATED PARTS NOT SHOWN  
 ENDCAP #BG-125EC

## BUMPER GUARD BG-125

IMPORTANT: USER SHALL VERIFY CONFORMANCE OF ALL CONSTRUCTIONS SHOWN WITH LOCAL CODES AND WITH REQUIREMENTS OF METAL STUD MANUFACTURER FOR RATINGS. FASTENERS AND PARTITION COMPONENTS NOT BY ARDEN ARCHITECTURAL SPECIALTIES, INC.

BUMPER GUARDS		DATE:	SCALE:
<u>GENERAL SPECIFICATION</u> RETAINER: ALUMINUM ALLOY TYPE 6063-T5, MILL FINISH .062" [1.57mm] THICK  COVER: HIGH-IMPACT VINYL ACRYLIC, IN ACCORDANCE WITH ASTM D 4226 AND ASTM D 256, .078" [1.98mm] THICK  CONTINUOUS LENGTH AVAILABLE: 20' [6.1M] MAXIMUM	PROJECT:		
	ARCHITECT:		
	CONTRACTOR:		
	REPRESENTATIVE:		



151 FIFTH AVE. NW SUITE J ST. PAUL, MN 55112-3268  
 TOLL-FREE 800.521.1826 TEL 651.631.1607 FAX 651.631.0251

CUSTOMER:	CUST. NO:	JOB NO:	SHEET OF
-----------	-----------	---------	----------