

# Wallwear® Integrated Wall Protection Systems

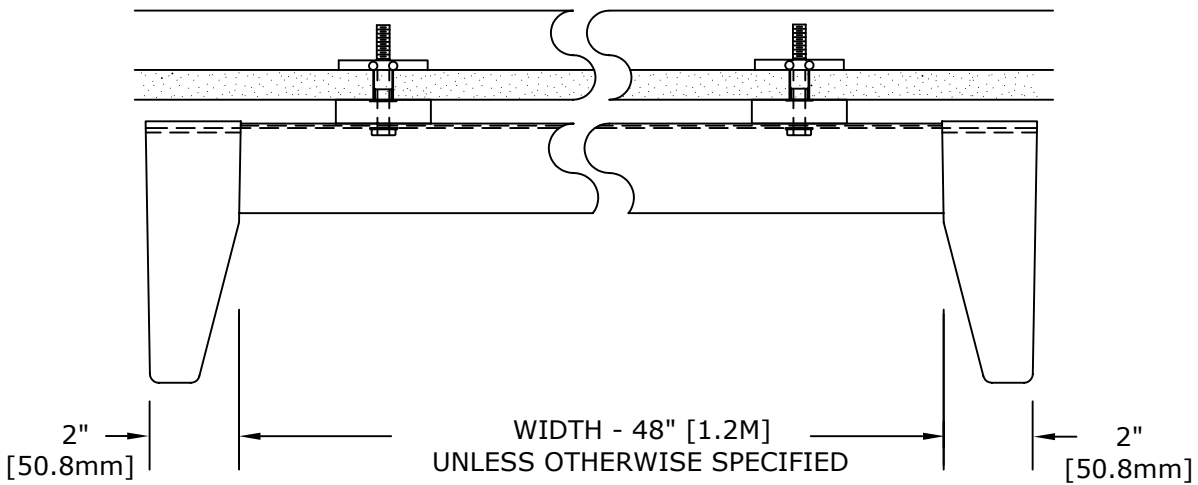
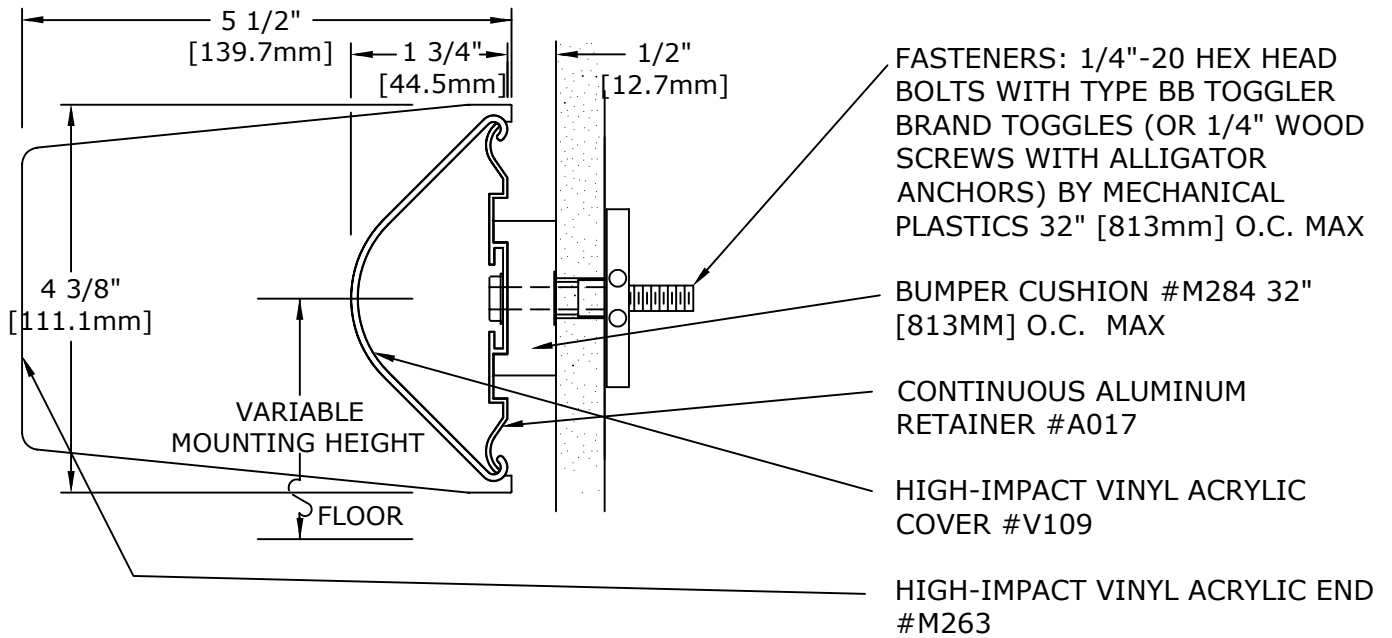

## BED LOCATOR BGL-4

IMPORTANT: USER SHALL VERIFY CONFORMANCE OF ALL CONSTRUCTIONS SHOWN WITH LOCAL CODES AND WITH REQUIREMENTS OF METAL STUD MANUFACTURER FOR RATINGS. FASTENERS AND PARTITION COMPONENTS NOT BY ARDEN ARCHITECTURAL SPECIALTIES, INC.

BED LOCATOR/BUMPER GUARDS		DATE:	SCALE:
<b>GENERAL SPECIFICATION</b> <b>RETAINER:</b> ALUMINUM ALLOY TYPE 6063-T5, MILL FINISH .062" [1.57mm] THICK  <b>COVER:</b> HIGH-IMPACT VINYL ACRYLIC, IN ACCORDANCE WITH ASTM D 4226 AND ASTM D 256, .078" [1.98mm] THICK  <b>CONTINUOUS LENGTH AVAILABLE:</b> 18' [5.49m] MAXIMUM		PROJECT:  ARCHITECT:  CONTRACTOR:  REPRESENTATIVE:	

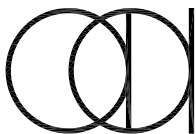

Arden  
Architectural  
Specialties, Inc.™

151 FIFTH AVE. NW SUITE J ST. PAUL, MN 55112-3268  
TOLL-FREE 800.521.1826 TEL 651.631.1607 FAX 651.631.0251

CUSTOMER:	CUST. NO:	JOB NO:	SHEET OF
-----------	-----------	---------	----------