

INSTALLATION INSTRUCTIONS CORNER GUARD SYSTEMS 1 HOUR RATING CGR-2S/1, -3S/1, -2R/1, -3R/1, 135/1

STORAGE, HANDLING & ENVIRONMENTAL CONDITIONS:

1. All materials shipped unassembled. Store vertically or on flat horizontal surface.
2. Begin installation only after finish construction has been completed and building interior has been within temperature range intended for continued use for at least 24 hours. Cut vinyl and aluminum components to fit only after they have been at temperature intended for continued use for 24 hours.

INSTALLATION:

1. Obtain code official's approval for rating required for project.
2. Field-verify that partition conforms with construction documents and codes having jurisdiction. Note: Tested and approved system utilized galvanized steel tie plates (24 ga., 1-1/2" x 5-1/2") secured directly to steel studs at mid-and quarter-points of partition height with 1/2" long self-drilling, self-tapping type S buglehead screws.
3. Install AASI fire barrier. Install with face containing integral wire mesh exposed. Align top of barrier with reference point "A" (see Standard Isometric Detail). Install fire barrier so that it completely covers all exposed portions of steel studs and other partition elements under corner guard. Use #6 type S buglehead sheet metal screws at each factory-drilled hole to secure barrier directly to steel studs. Apply continuous 1/2" diameter bead of manufacturer-provided fire caulk along all edges of fire barrier.
4. Field-verify exact retainer lengths for height of wall or partition.
5. Install retainers. Moisten inside of aluminum base molding with spray lubricant to facilitate installation of aluminum base molding, and slide onto one end of aluminum retainer. This end will sit on floor. Secure retainer to wall or partition with fasteners inserted through factory-drilled holes in retainer legs. For most drywall applications, we recommend #6 drywall screws, fastened through gypsum board to studs. For most masonry applications, we recommend #6 drywall screws and Toggler brand "alligator" anchors, size A5, by Mechanical Plastics.
6. Install cover. Field-verify that cover lengths fit exactly between top of aluminum base molding and top of system, as shown or specified. Use one continuous length of vinyl acrylic cover per corner. Secure to retainer by hooking over lip on one retainer leg and snapping over lip on other retainer leg.
7. Cleaning: use mild detergent to clean soiled surfaces. Do not use powdered cleansers, as they may leave a residue on cover surface.

PARTS LIST

CGR-2S/1, -3S/1, -2R/1, -3R/1, 135/1

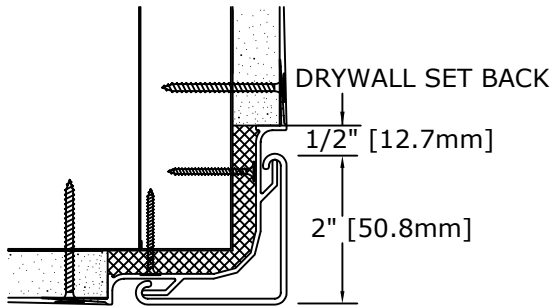

CGR-2S/1

- FIRE CAULK - #CP25WB
- FIRE BARRIER - #FB303
- ALUMINUM RETAINER - #A040
- VINYL ACRYLIC COVER #V106
- ALUM. BASE MOLDING - #A027

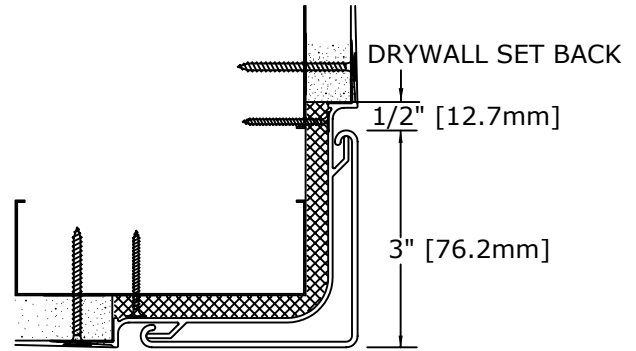

CGR-3S/1

- FIRE CAULK - #CP25WB
- FIRE BARRIER - #FB304
- ALUMINUM RETAINER - #A041
- VINYL ACRYLIC COVER - #V107
- ALUM. BASE MOLDING - #A028

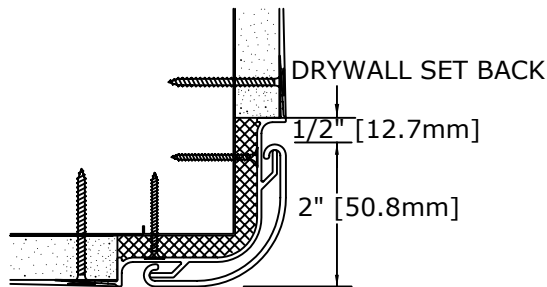

CGR-2R/1

- FIRE CAULK - #CP25WB
- FIRE BARRIER - #FB303
- ALUMINUM RETAINER - #A040
- VINYL ACRYLIC COVER - #V108
- ALUM. BASE MOLDING - #A029

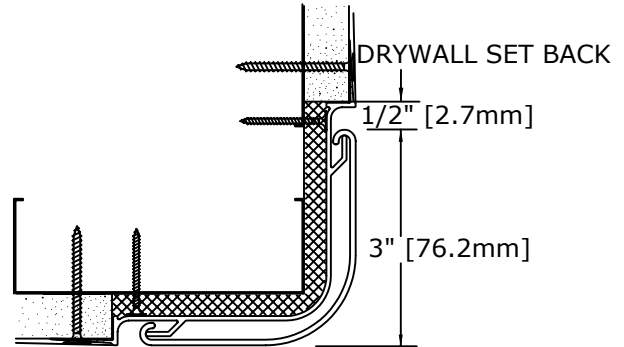

CGR-3R/1

- FIRE CAULK - #CP25WB
- FIRE BARRIER - #FB304
- ALUMINUM RETAINER - #A041
- VINYL ACRYLIC COVER - #V109
- ALUM. BASE MOLDING - #A030

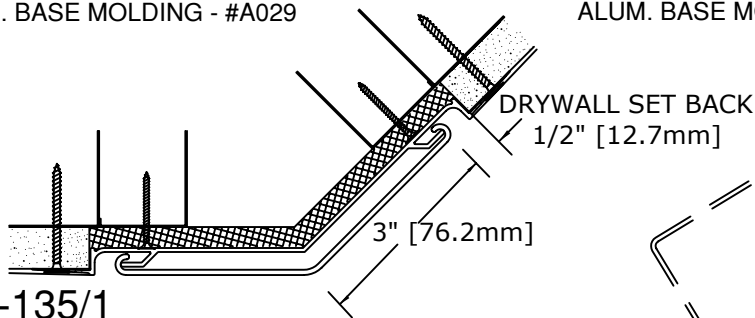

CGR-135/1

- FIRE CAULK - #CP25WB
- FIRE BARRIER - #FB305
- ALUMINUM RETAINER - #A042
- VINYL ACRYLIC COVER - #V110
- ALUM. BASE MOLDING - #A031

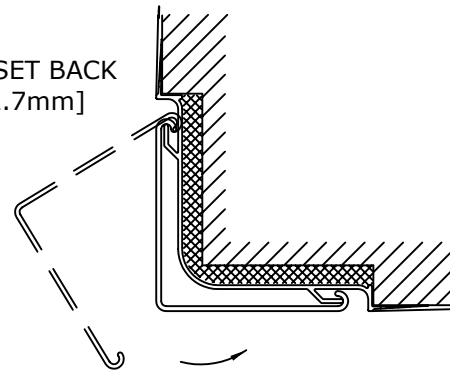

COVER INSTALLATION

1. HOOK OVER ONE RETAINER LIP.
2. ROTATE SIDEWARD, PUSHING FIRMLY TO SNAP OVER OTHER RETAINER LIP.

TYPICAL ASSEMBLY DRAWING

CGR-2S/1, -3S/1, -2R/1, -3R/1, 135/1

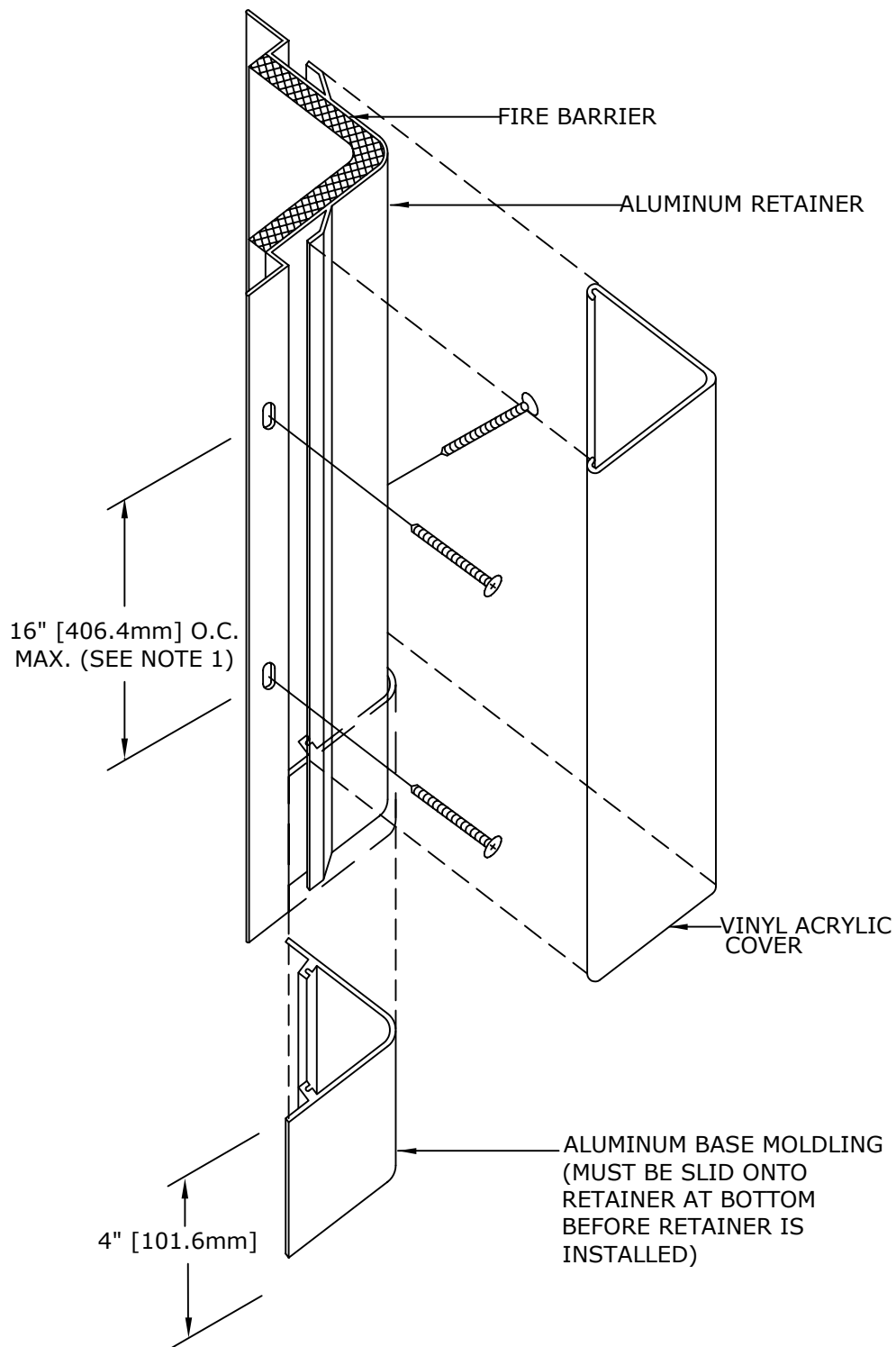

NOTES:

1. FACTORY-DRILLED FASTENER HOLES ON RETAINER LEGS ARE STAGGERED 8" [203.2mm] O.C. MAX. (HOLES ON EACH LEG ARE SPACED 16" [406.4mm] O.C. MAX.)

STANDARD ISOMETRIC DETAIL

CGR-2S/1, -3S/1, -2R/1, -3R/1, 135/1

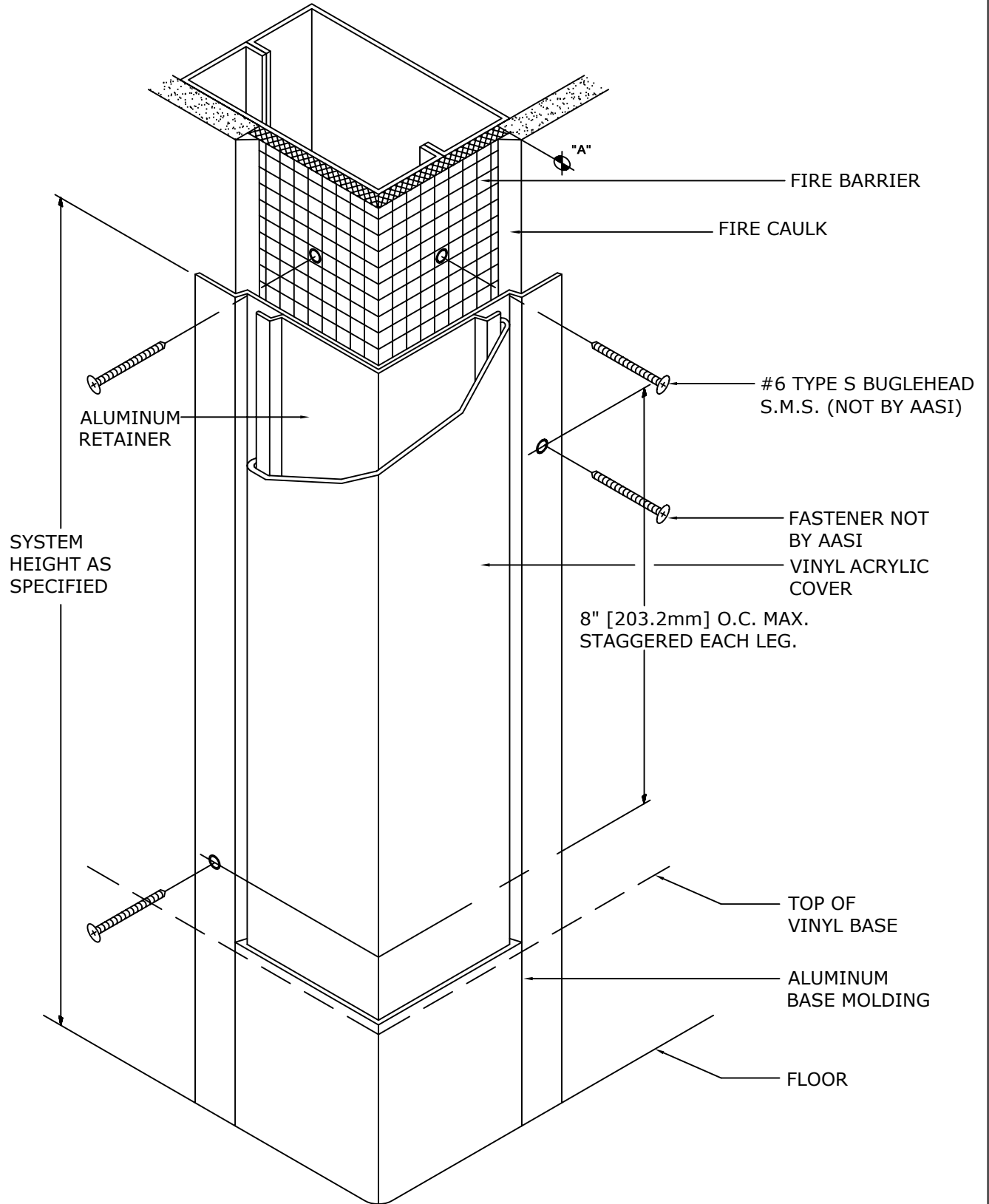

151 FIFTH AVE. NW SUITE J ST. PAUL, MN 55112-3268
TOLL-FREE 800.521.1826 TEL 651.631.1607 FAX 651.631.0251

ARDEN Architectural
SPECIALTIES INC.

PLAN VIEW

CGR-2S/1, -3S/1, -2R/1, -3R/1 (CGR-3S/1 SHOWN)

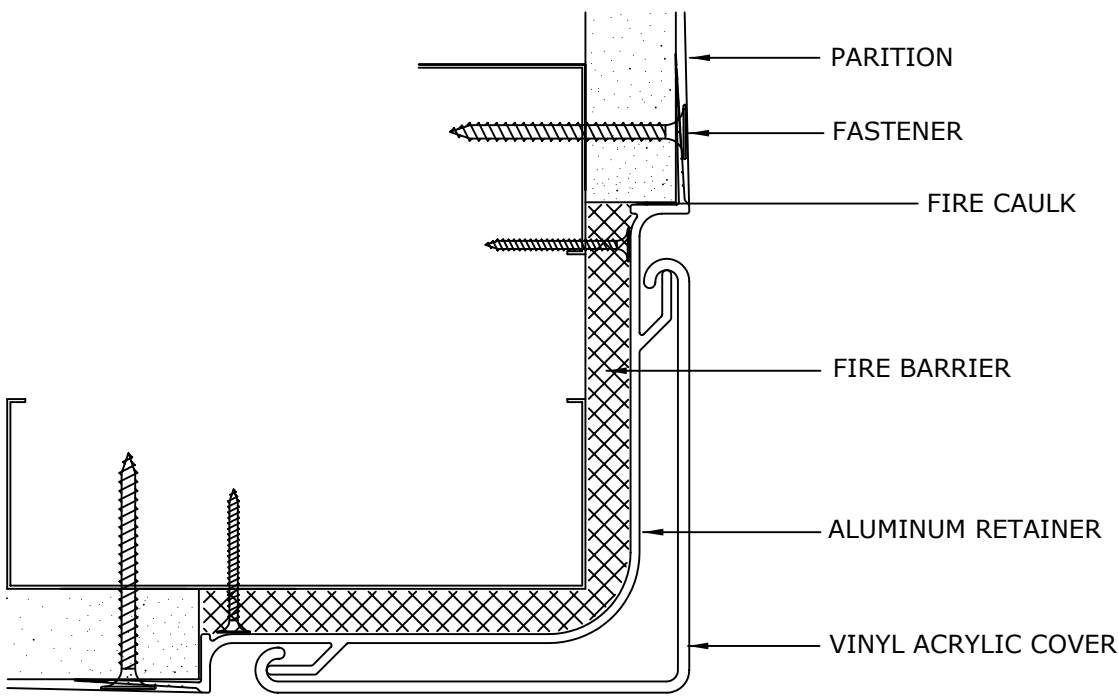

NOTES:
1. REFER TO INSTALLATION INSTRUCTIONS AND
DETAIL SHEETS FOR MORE INFORMATION,
INCLUDING PART NUMBERS.

IMPORTANT: USER SHALL VERIFY CONFORMANCE OF ALL CONSTRUCTIONS SHOWN WITH LOCAL CODES AND WITH REQUIREMENTS OF METAL STUD MANUFACTURER FOR RATINGS. FASTENERS AND PARTITION COMPONENTS NOT BY ARDEN ARCHITECTURAL SPECIALTIES, INC.

TYPICAL FASTENING CONDITIONS SHOWN BELOW

<p>1 LAYER GYP. BD.</p> <p>#6 x 2" DRYWALL SCREW</p> <p>QTY:</p>	<p>2 LAYERS GYP. BD.</p> <p>#6 x 2" DRYWALL SCREW</p> <p>QTY:</p>	<p>GYP. BD. & MASONRY</p> <p>#6 X 1-1/2" S.M. SCREW AND TYPE AF5 ALLIGATOR ANCHORS BY MECHANICAL PLASTICS</p> <p>QTY:</p>
--	---	---

SPECIFICATION:

GENERAL: FURNISH AND INSTALL CORNER GUARD SYSTEM(S) BY ARDEN ARCHITECTURAL SPECIALTIES, INC., AS SHOWN AND SPECIFIED.

INSTALLATION: SECURE TO WALL OR PARTITION IN ACCORDANCE WITH MANUFACTURER'S PRINTED INSTRUCTIONS. USE FASTENERS DESIGNED AND APPROVED FOR PURPOSE INTENDED, SPACED 8 INCHES [203.2mm] O.C. MAX. STAGGERED EACH LEG OF RETAINER. INSTALL IN ACCORDANCE WITH ALL CODES HAVING JURISDICTION.

151 FIFTH AVE. NW SUITE J ST. PAUL, MN 55112-3268
TOLL-FREE 800.521.1826 TEL 651.631.1607 FAX 651.631.0251

