

## G-100RS GRATE DETAIL

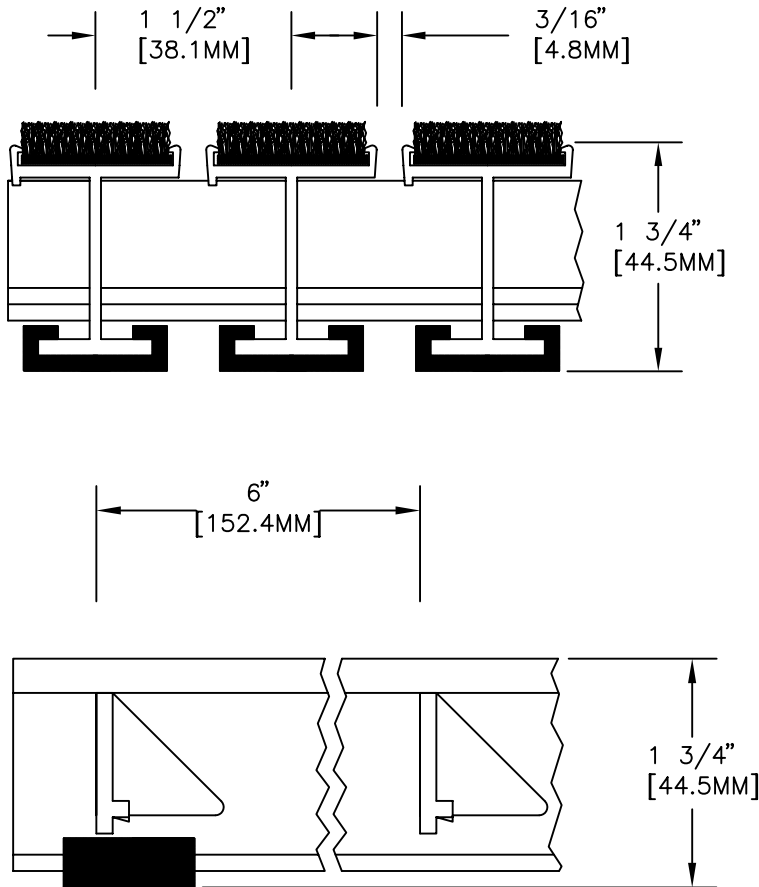

*Mechanically joined keylock every six inches makes Arden Architectural's standard grates the strongest grates of their type on the market. Rugged Scrub<sup>®</sup> treads work like scrubbers to effectively remove dirt and moisture. They are suitable for interior and exterior use, and don't develop traffic patterns like carpet treads. This product carries a five-year warranty.*

### DETAIL NOTES:

- 1 - Tread rails must run perpendicular to traffic direction.
- 2 - Traffic direction dimension can only be changed in 1-1/2" (38.1mm) increments unless aluminum filler is attached to the frame.
- 3 - Grate dimensions allow for clearance between grate sections and frames in the width dimension.

### SPECIFICATION:

GrateDesign G-100RS Rugged Scrub tread grate by Arden Architectural Specialties, Inc.; with 1-3/4" (44.5mm) deep, 6063-T52 aluminum alloy rails, with treads of 600 denier polypropylene, tufted, with primary and secondary backing; spaced 1-1/2" (38.1mm) o.c.; with keylocks spaced [6" (152.4mm)] [3" (76.2mm)] o.c.; use with aluminum [type F-1 level-bed] [type F-LANG large angle] [type F-2 deep pit] [type F-2T thin slab] frame.

Complete specifications available on our website at [www.ardenarch.com](http://www.ardenarch.com).

CUST. ORDER #		ARCHITECT		 Arden Architectural Specialties, Inc. <sup>™</sup> 151 FIFTH AVE. NW SUITE J ST. PAUL, MN 55112-3268 TOLL-FREE 800.521.1826 TEL 651.631.1607 FAX 651.631.0251
CUSTOMER		CONTRACTOR		
PROJECT	RAIL MODEL <b>G-100RS</b>	FRAME MODEL <b>N/A</b>	SCALE <b>NTS</b>	