

*Mechanically joined keylock every six inches makes Arden Architectural's standard grates the strongest grates of their type on the market. Optional three-inch spacing is available for grates in areas with heavy rolling loads.*

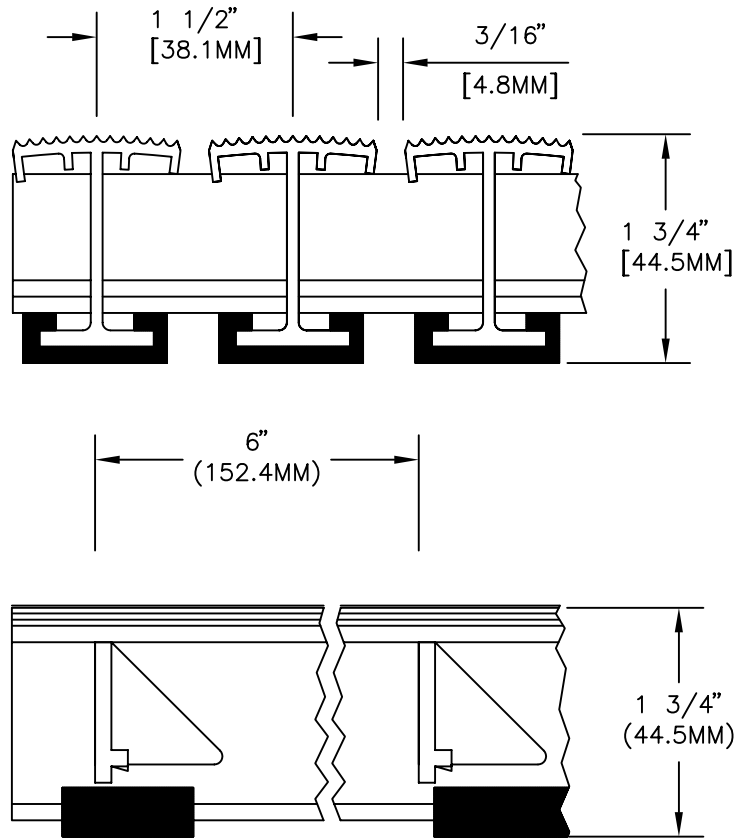

**DETAIL NOTES:**

- 1 - Tread rails must run perpendicular to traffic direction.
- 2 - Traffic direction dimension can only be changed in 1-1/2" (38.1mm) increments unless aluminum filler is attached to the frame.
- 3 - Grate dimensions allow for clearance between grate sections and frames in the width dimension.

**SPECIFICATION:**

GrateDesign model G-500 serrated aluminum tread grate by Arden Architectural Specialties, Inc.; with 1-3/4" (44.5mm) deep, 6063-T52 aluminum alloy rails, with continuous serrations; spaced 1-1/2" (38.1mm) o.c.; with keylocks spaced [6"(152.4mm)][3"(76.2mm)] o.c.; use with aluminum [type F-1 level-bed][type F-LANG large angle][type F-2 deep pit][type F-2T thin slab] frame.

Complete specifications available on our website at [www.ardenarch.com](http://www.ardenarch.com).

CUST. ORDER #	ARCHITECT			 Arden Architectural Specialties, Inc. <sup>™</sup> 151 FIFTH AVE. NW SUITE J ST. PAUL, MN 55112-3268 TOLL-FREE 800.521.1826 TEL 651.631.1607 FAX 651.631.0251
CUSTOMER	CONTRACTOR			
PROJECT	RAIL MODEL G-500	FRAME MODEL N/A	SCALE NTS	