

EnvIRONtread® II grates are recycled, reversible and sustainable. The double-sided buffed rubber from recycled nylon-reinforced truck and airplane tires will outlast any other tread insert. The sturdy aluminum divider bars are also recycled. Durability and effectiveness ensure low life-cycle costs. This product carries a five year warranty.

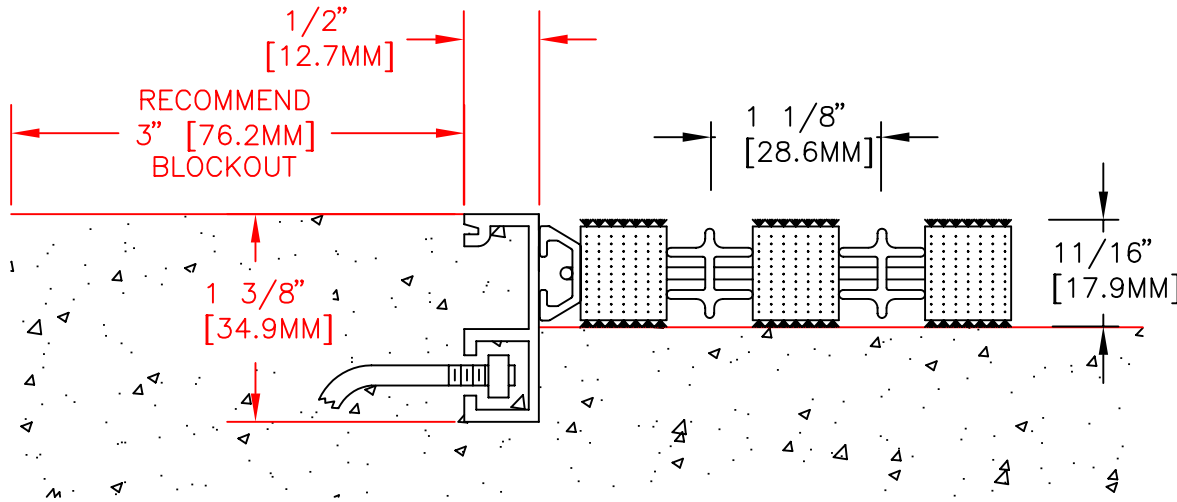

DETAIL NOTES:

1 - Tread rails must run perpendicular to traffic direction.

SPECIFICATION:

GrateDesign G-218 double sided buffed rubber tread grate by Arden Architectural Specialties, Inc.; with 11/16" (17.9mm) deep, alternating 6063-T52 aluminum alloy divider bars and recycled buffed rubber treads; spaced 1-1/8" (28.6mm) o.c.; use with [recessed type F-11] frame.

Complete specifications available on our website at www.ardenarch.com.

CUST. ORDER #	ARCHITECT			 Arden Architectural Specialties, Inc.™ 151 FIFTH AVE. NW SUITE J ST. PAUL, MN 55112-3268 TOLL-FREE 800.521.1826 TEL 651.631.1607 FAX 651.631.0251
CUSTOMER	CONTRACTOR			
PROJECT	RAIL MODEL G-218	FRAME MODEL F-11	SCALE NTS	