

*EnvIRONtread®II grates are recycled, reversible and sustainable. The double-sided buffed rubber from recycled nylon-reinforced truck and airplane tires will outlast any other tread insert. The sturdy aluminum divider bars are also recycled. Durability and effectiveness ensure low life-cycle costs. This product carries a five-year warranty.*

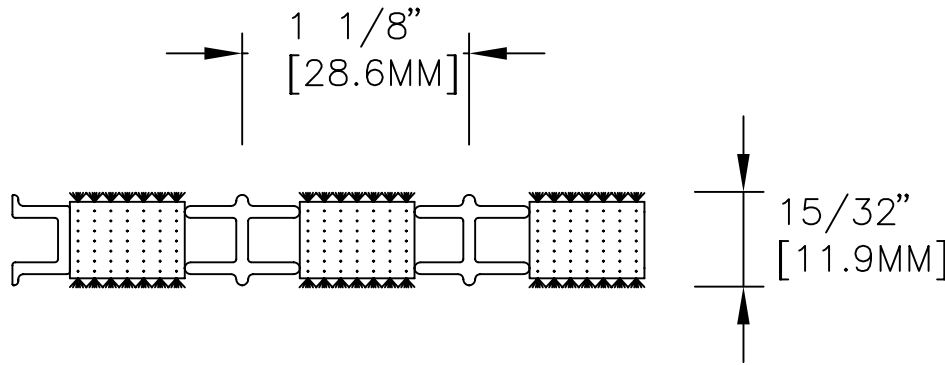

**DETAIL NOTES:**

- 1 - Tread rails must run perpendicular to traffic direction.
- 2 - Grate dimensions allow for clearance between grate sections and frames in the width dimension.

**SPECIFICATION:**

Model G-212 EnvIRONtread II grate by Arden Architectural Specialties, Inc.; with 15/32" (11.9mm) deep, alternating 6063-T52 aluminum alloy divider bars and recycled buffed rubber treads; spaced 1-1/8" (28.6mm) o.c.; use with [type F-13 aluminum recessed][type F-12 aluminum surface mounted]frame.

Complete specifications available on our website at [www.ardenarch.com](http://www.ardenarch.com).

CUST. ORDER #	ARCHITECT			 Arden Architectural Specialties, Inc.™ 151 FIFTH AVE. NW SUITE J ST. PAUL, MN 55112-3268 TOLL-FREE 800.521.1826 TEL 651.631.1607 FAX 651.631.0251
CUSTOMER	CONTRACTOR			
PROJECT	RAIL MODEL G-212	FRAME MODEL N/A	SCALE NTS	