

Striations cut perpendicular to the tread rails create a clean grid pattern that removes dirt regardless of the direction traffic passes. Constructed with sturdy keylocks every three inches, Thin Line grates can stand up to almost any traffic. These grates cannot be fabricated with curves and angles.

DETAIL NOTES:

- 1 - Tread rails must run perpendicular to traffic direction.
- 2 - Traffic direction dimensions can only be changed in 3/4" (19.1mm) increments unless aluminum filler is attached to the frame.
- 3 - Grate dimensions allow for clearance between grate sections and frames in the width dimension.

SPECIFICATION:

GrateDesign model G-550 thin line [aluminum][architectural bronze]waffle grate by Arden Architectural Specialties, Inc.; with 1-3/4" (44.5mm) deep, [6063-T52 aluminum alloy rails][385 bronze alloy], spaced 3/4" (19.1mm) o.c.; with keylocks spaced 3" (76.2mm) o.c.; use with [type F-1 level bed][type F-LANG large angle][type F-2 deep pit][type F-2T thin slab] frame.

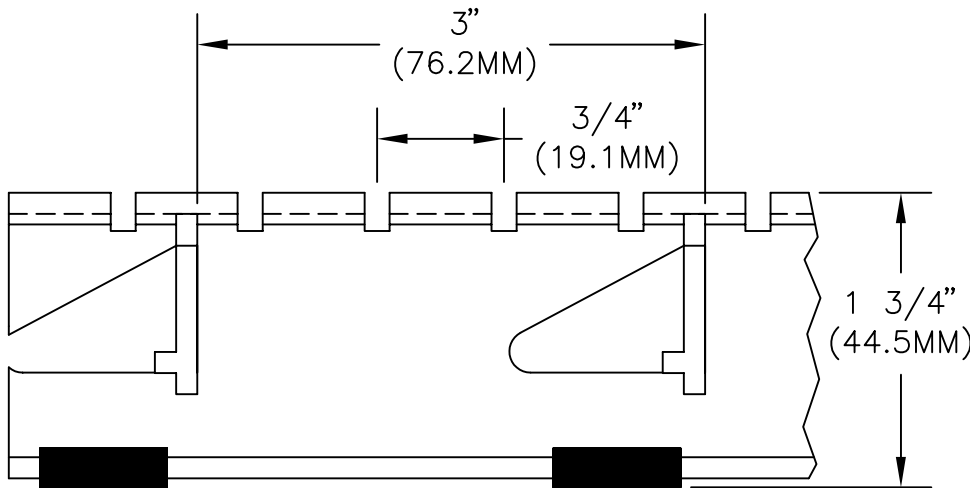

Complete specifications available on our website at www.ardenarch.com.

CUST. ORDER #	ARCHITECT			 Arden Architectural Specialties, Inc.™ 151 FIFTH AVE. NW SUITE J ST. PAUL, MN 55112-3268 TOLL-FREE 800.521.1826 TEL 651.631.1607 FAX 651.631.0251
CUSTOMER	CONTRACTOR			
PROJECT	RAIL MODEL G-550	FRAME MODEL N/A	SCALE NTS	