

G-525RS / G-525U GRATE DETAIL

Arden Architectural's ScrapesGrate® entrance grates have scraper bars that alternate with either absorbent UltraSorb® tread for indoor use or heavy-duty Rugged Scrub® tread for outdoor use. Water and dirt are scraped off and funnelled under the mat at the door so the floor stays clean. This product carries a five-year warranty.

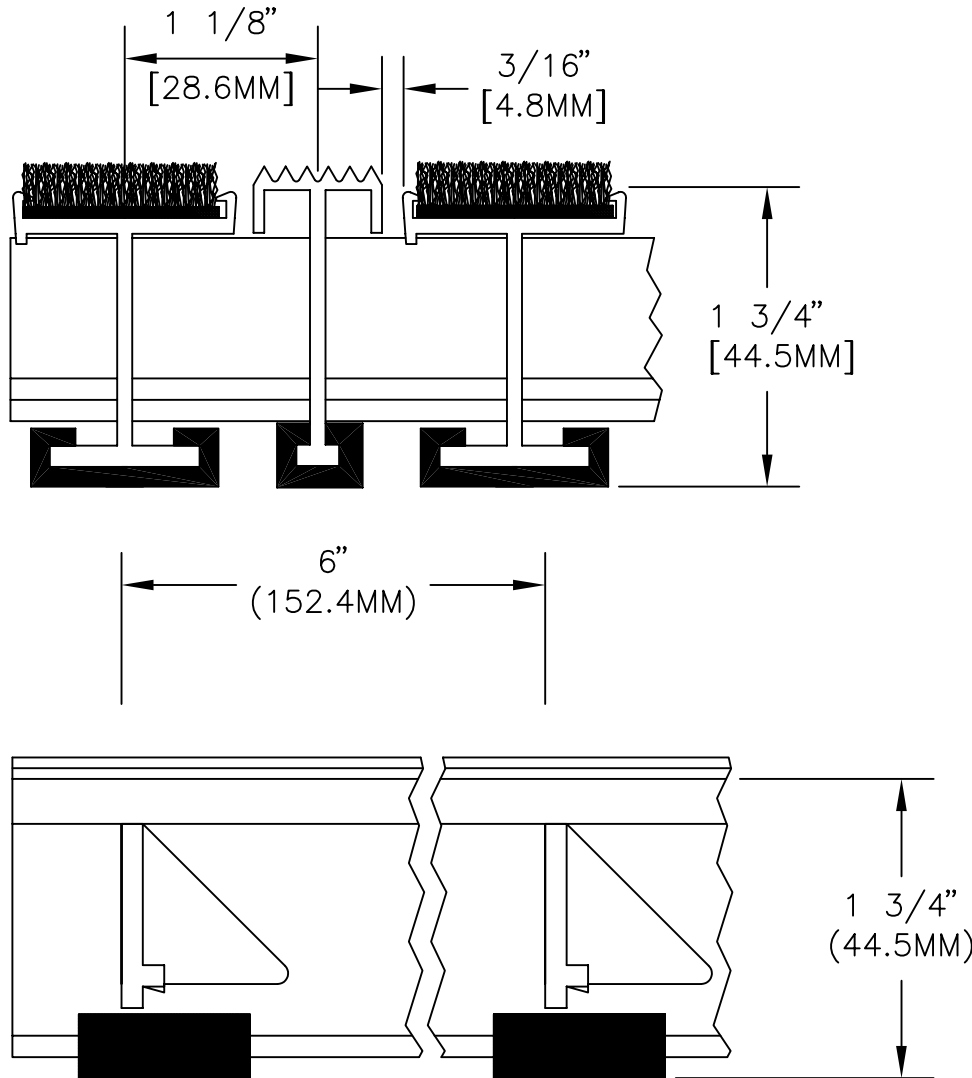

DETAIL NOTES:

- 1 - Tread rails should run perpendicular to traffic direction.
- 2 - Dimensions in the traffic direction can only be changed in limited increments unless aluminum filler is attached to the frame.
- 3 - Grate dimensions allow for clearance between grate sections and frames in the width dimension.

SPECIFICATION:

ScrapesGrate model [G-525RS] [G-525U] grate by Arden Architectural Specialties, Inc.; with 1-3/4" (44.5mm) deep, 6063-T52 aluminum alloy rails alternating with aluminum scraper bars; spaced 1-1/8" (28.6mm) o.c.; with [600 denier tufted polypropylene Rugged Scrub tread] [80 d'tex and 40 d'tex tufted nylon UltraSorb tread]; with keylock spaced every [6" (152.4mm)] [3" (76.2mm)] o.c.; use with aluminum [type F-1 level-bed][type F-LANG large angle][type F-2 deep pit][type F-2T thin slab] frame.

Complete specifications available on our website at www.ardenarch.com.

CUST. ORDER #	ARCHITECT			 Arden Architectural Specialties, Inc.™ 151 FIFTH AVE. NW SUITE J ST. PAUL, MN 55112-3268 TOLL-FREE 800.521.1826 TEL 651.631.1607 FAX 651.631.0251
CUSTOMER	CONTRACTOR			
PROJECT	RAIL MODEL G-525 RS / U	FRAME MODEL N/A	SCALE NTS	